

Quick reference sheet for the CreaTe ProtoBox

<http://fritzing.org>
<http://arduino.cc>

Version 1.1 - E13 - 2012

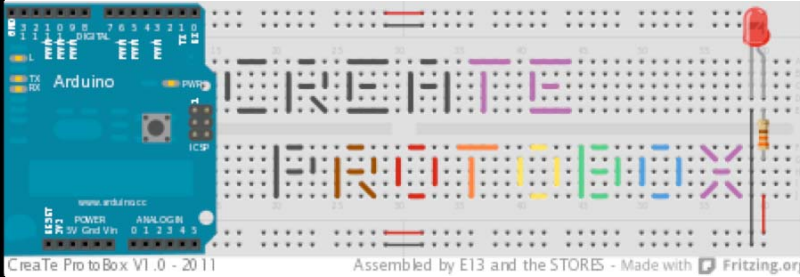

- Core:**
- 1 Arduino Uno
 - 1 USB A-B cable
 - 1 Breadboard
 - 1 Set wires

- Support:**
- 10 Resistor 330R
 - 4 Resistor 1k
 - 4 Resistor 10k
 - 8 Resistor 100k
 - 8 Resistor 220k
 - 4 Resistor 10M
 - 2 Transistor BC337
 - 1 OpAmp TL272
 - 2 Diode 1N4148
 - 2 Capacitor 100nF
 - 2 Capacitor 10uF

- Output:**
- 1 Piezo Buzzer
 - 1 LED RGB
 - 2 LED Blue
 - 2 LED Green
 - 2 LED Yellow
 - 2 LED Red
 - 1 LED IR
 - 1 DC motor

- Input:**
- 1 Microphone
 - 1 NTC
 - 1 CNY70 refl. sensor
 - 1 IR sensor 38kHz
 - 1 LDR
 - 2 Pushbutton
 - 1 Potentiometer

LED

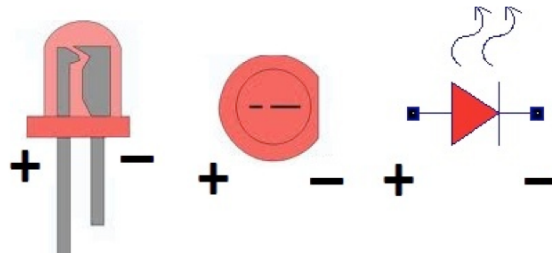

Note polarity!
 Also use a series resistor. LED's can take 20mA.
 In most cases 330R is good enough.

Resistor

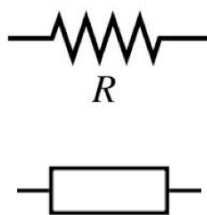

Color	Color Name	1 st digit 1 st stripe	2 nd digit 2 nd stripe	Multiplier 3 rd stripe	Tolerance 4 th stripe
Black	0	0	0	x1	-
Brown	1	1	1	x10	1%
Red	2	2	2	x100	2%
Orange	3	3	3	x1,000	3%
Yellow	4	4	4	x10,000	4%
Green	5	5	5	x100,000	-
Blue	6	6	6	x1,000,000	-
Violet	7	7	7	-	-
Grey	8	8	8	-	-
White	9	9	9	-	-
Gold	-	-	-	x0.1	5%
Silver	-	-	-	x0.01	10%

Resistors do not have polarization. Colored rings are used to denote the value. Ohm's law applies: $V=I \cdot R$

Pushbutton



(switch)

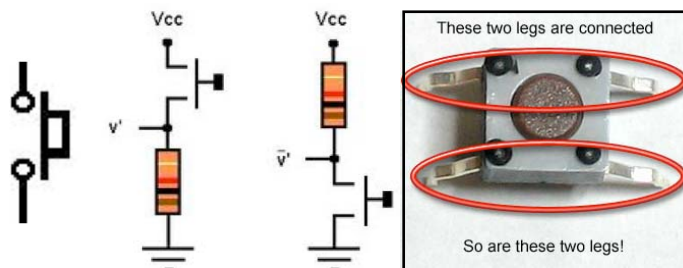

A switch can be connected using a 10k pull-up resistor. (or pull-down)
 You might have to straighten the legs to fit the breadboard

Potentiometer 10k

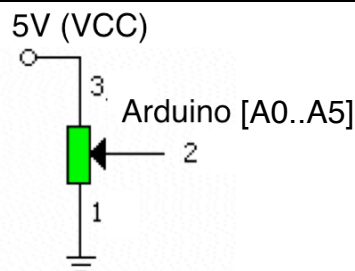
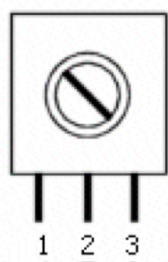

10k Potentiometer
 Can be connected to analog input, or can be used to reduce an analog signal.

Electret Microphone



This microphone needs a voltage using a [1..2.2k] pull-up resistor, decoupling capacitor and an amplifier circuit.

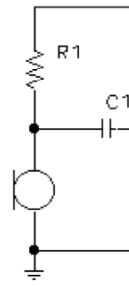

Note polarity!

The negative side is connected with the casing (see backside)

220x amplifier + offset voltage. The 100nF capacitor works as high-pass filter

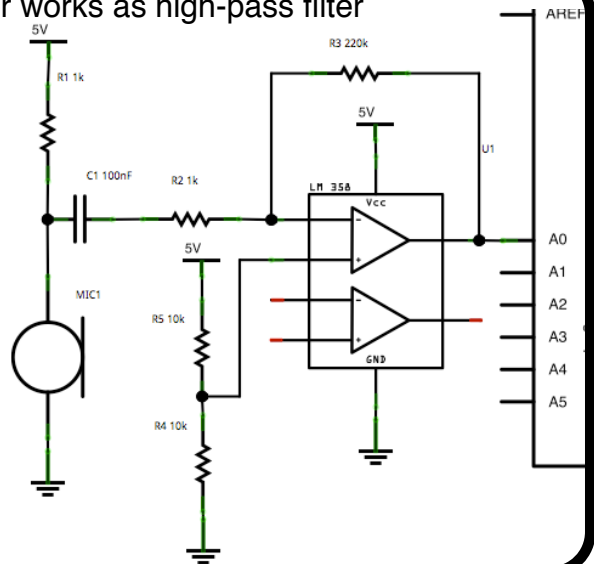
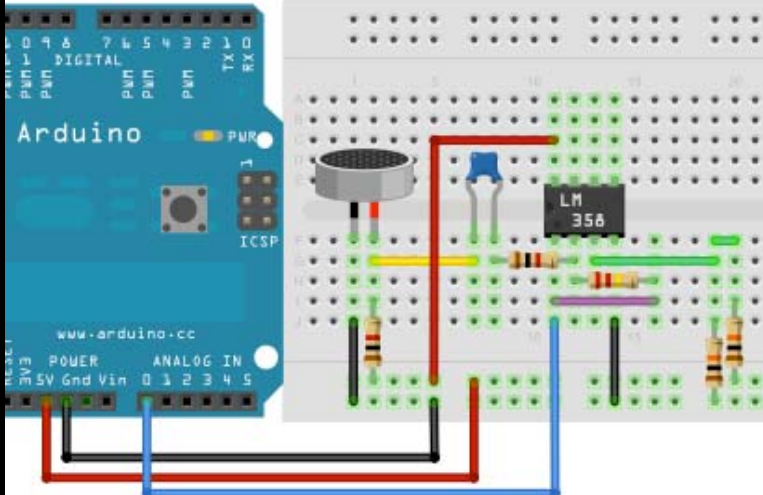

TL272 OpAmp (LM358 is compatible)



OpAmp stands for 'operational amplifier'.

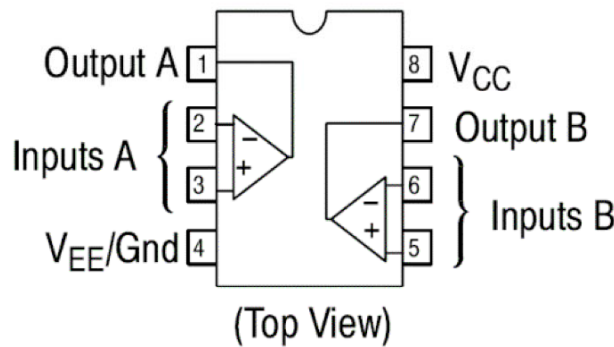

The polarization is given using a dot on the first pin, the small notch also denotes the side with pin 1. The chip contains two OpAmps and requires a supply voltage of at least 5V

Ceramic capacitor 100 nF

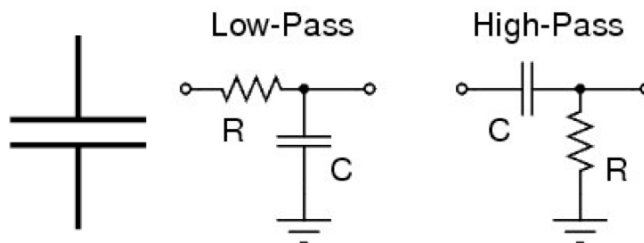

This is a small capacitor, used in analog signal schematics. It has no polarization. Mostly used in RC-networks as filter.

Touch sensor

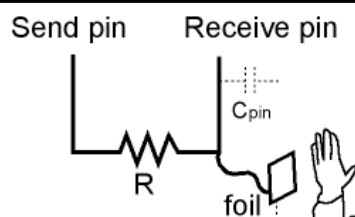
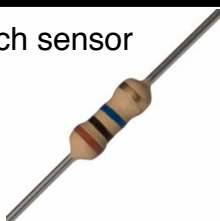

Using the large 10M resistor and two Arduino pins you can make a capacitive touch sensor. Check <http://www.arduino.cc/playground/Main/CapSense>

RGB LED

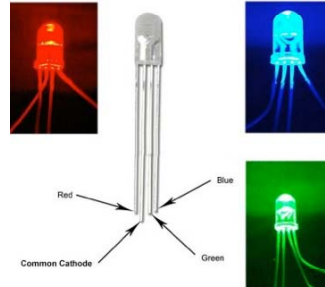
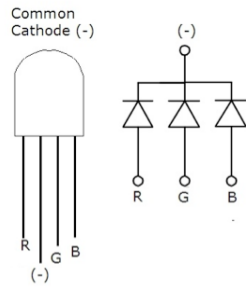

An RGB LED contains three separate LED's which share a common cathode(-)

IR LED

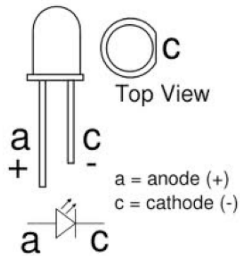

Connection is the same as with normal LED's. This LED can be used to mimic your IR remote signals using Arduino library IRremote.h

Note polarity! Light of this LED is not visible with the eye. Most digital camera's can detect IR. Also use a series resistor.

TSOP4838 IR receiver

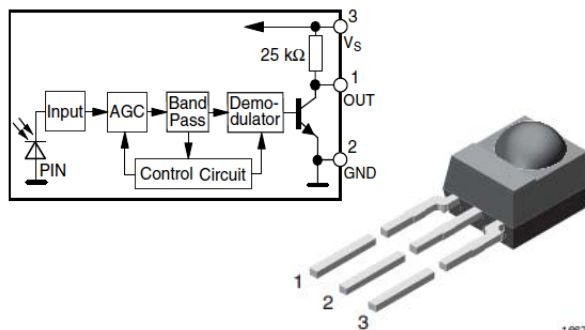

This sensor can detect and decode IR signals sent by a remote control. Use Arduino library IRremote.h by Ken Shirriff to decode most of the available remotes. Connect sensor OUT to an Arduino input.

Electrolytic capacitor 10 uF

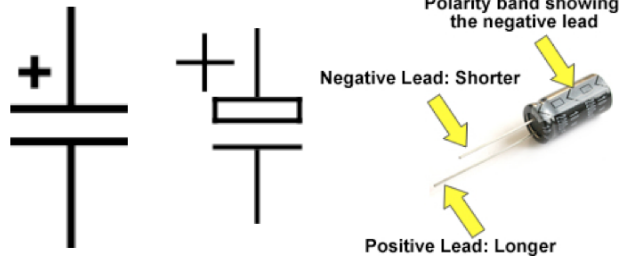

This is the larger capacitor, also used in analog signal schematics and power supply stabilization. Note the polarization!

LDR



(Light sensor)

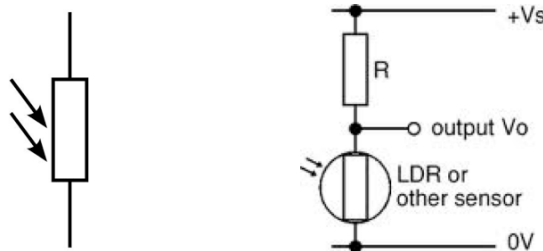

An LDR has no polarity. It can be connected using a pull-up resistor of 10k to an Arduino input.

NTC resistor



(temperature sensor)



The NTC resistor needs a pull-up resistor of 10k. It can detect temperatures between -55 and +125 degrees C. The resistor has a value of 100k at room temperature

The NTC resistor has no polarization, it is a resistive sensor.

BC337 transistor (NPN)

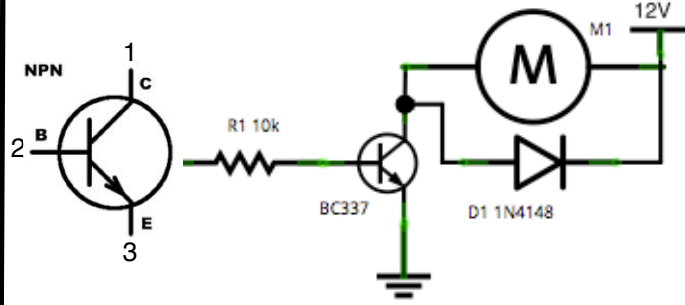

Note polarity and pinning. Use this transistor to amplify signals or switch loads up to 1A at 35V (max). Use a reverse diode to prevent back EMF

Piezo buzzer



When amplification of the beeps is necessary, the transistor circuit described here can be used. Also making a physical (horn) shape around the buzzer can increase the volume...

Piezo buzzer can be connected directly to Arduino's output pins. Use the tone library (build in) to make beeps. Connect to (-) and to an output pin.

1N4148 diode

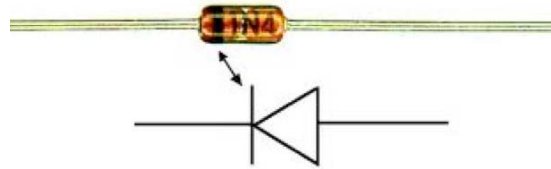

Note polarity. Diodes conduct current only in one way (when the stripe is connected to a (-), it will conduct)

CNY 70 reflection sensor

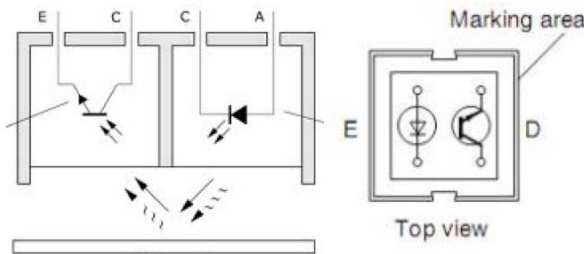

This sensor contains one phototransistor and one IR LED. Together they act as reflection sensor. Use a series resistor with the LED and a pull-up resistor for the transistor. The wires should be bent

Interfacing the CNY70 reflective sensor

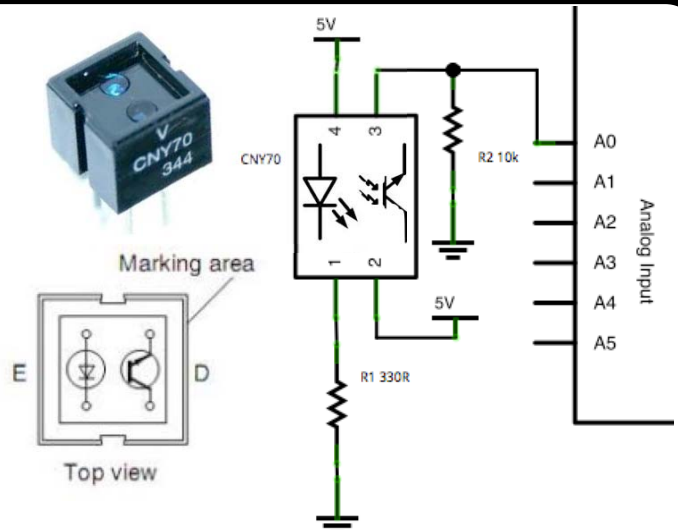
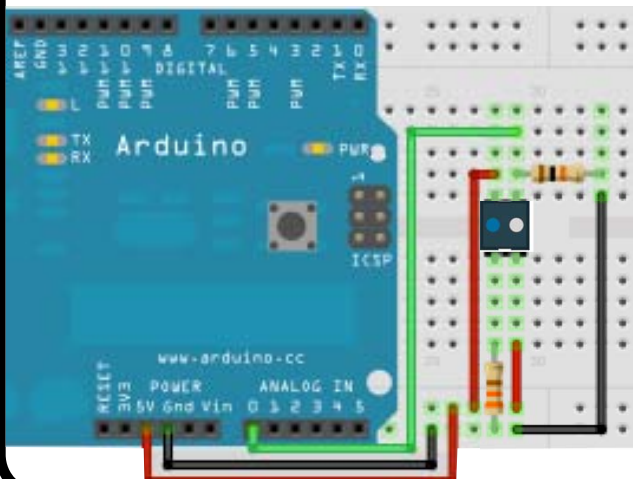

Phototransistor

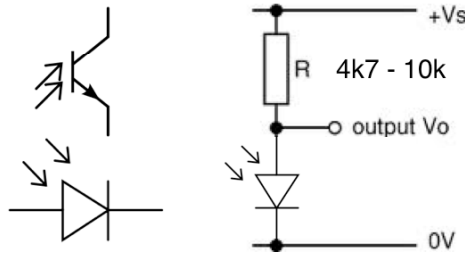

Note polarity. The same markings used with an LED apply, although the wire length is different. A phototransistor or photodiode conducts current depending on received light intensity. Use a pull-up resistor.

Breadboard

The horizontal rows are called 'rail' and are mostly used for connecting power and ground. Note that on larger breadboards there can be one or more gaps in these rails.

The vertical columns are used to connect the components. They are grouped in rows of 5 connection points.

Breadboards do not have infinite life, connections can become flaky over time,

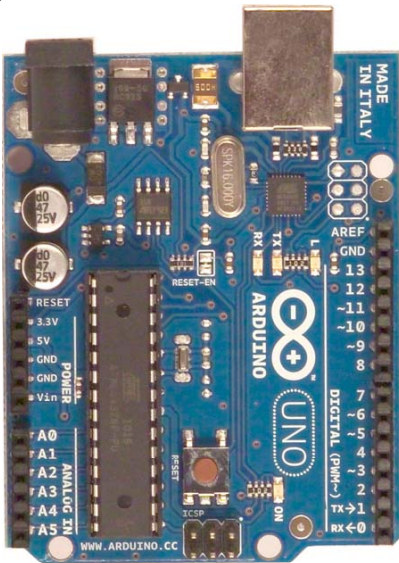
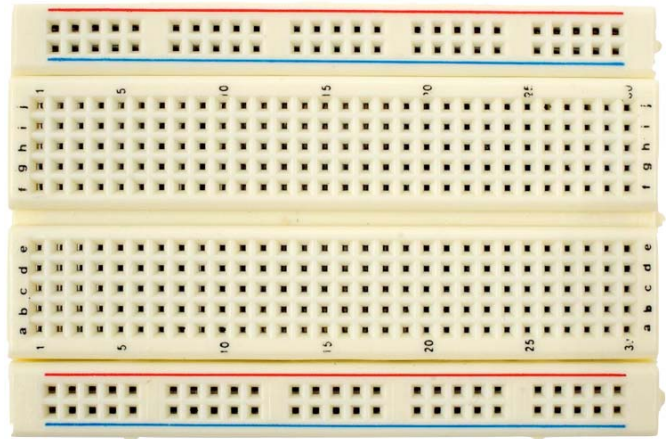

Atmega168 Pin Mapping

Arduino function	ATmega168 Pin	ATmega168 Pin	Arduino function
reset	(PCINT14/RESET) PC6	1	PC5 (ADC5/SCL/PCINT13) analog input 5
digital pin 0 (RX)	(PCINT16/RXD) PD0	2	PC4 (ADC4/SDA/PCINT12) analog input 4
digital pin 1 (TX)	(PCINT17/TXD) PD1	3	PC3 (ADC3/PCINT11) analog input 3
digital pin 2	(PCINT18/INT0) PD2	4	PC2 (ADC2/PCINT10) analog input 2
digital pin 3 (PWM)	(PCINT19/OC2B/INT1) PD3	5	PC1 (ADC1/PCINT9) analog input 1
digital pin 4	(PCINT20/XCK/T0) PD4	6	PC0 (ADC0/PCINT8) analog input 0
VCC	VCC	7	GND
GND	GND	8	AREF analog reference
crystal	(PCINT6/XTAL1/TOSC1) PB6	9	AVCC VCC
crystal	(PCINT7/XTAL2/TOSC2) PB7	10	PB5 (SCK/PCINT5) digital pin 13
digital pin 5 (PWM)	(PCINT21/OC0B/T1) PD5	11	PB4 (MISO/PCINT4) digital pin 12
digital pin 6 (PWM)	(PCINT22/OC0A/AIN0) PD6	12	PB3 (MOSI/OC2A/PCINT3) digital pin 11 (PWM)
digital pin 7	(PCINT23/AIN1) PD7	13	PB2 (SS/OC1B/PCINT2) digital pin 10 (PWM)
digital pin 8	(PCINT0/CLKO/ICP1) PB0	14	PB1 (OC1A/PCINT1) digital pin 9 (PWM)

Digital Pins 11, 12 & 13 are used by the ICSP header for MISO, MOSI, SCK connections (Atmega168 pins 17, 18 & 19). Avoid low-impedance loads on these pins when using the ICSP header.



NE555 timer

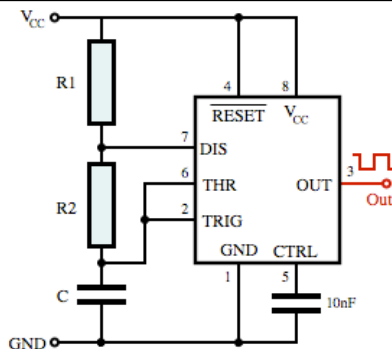
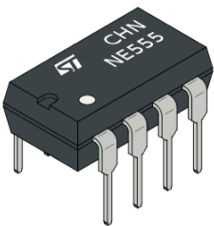

Versatile timing chip. Can be used to make oscillators, PWM generators, delay timers etc. In this circuit:

$$\text{Frequency} = 1.44 / (R_1 + 2R_2) C \text{ [Hz]}$$

$$\text{Dutycycle} = R_2 / (R_1 + 2R_2) \text{ [%]}$$

Checkout http://en.wikipedia.org/wiki/555_timer_IC